



G3687CF

Fast Turn-Off Intelligent Synchronous Rectifier

1. General Description

G3687CF is a high performance and highly integrated secondary side synchronous rectification controller used for secondary side rectification in switch mode power supply system. it can replace Schottky diode for high efficiency by connecting with an lower voltage drop N-channel MOSFET, and meet the requirement of DOE VI & COC energy efficiency.

It is suitable for multiple mode applications including discontinuous conduction mode (DCM), quasi-resonant mode (QR) and continuous conduction mode (CCM). The Drain-to-source voltage (V_{SW}) of SR MOSFET is sensed to control the turn on and off of the SR MOSFET. G3687CF can generate its own supply voltage for battery charging applications with potential low output voltage, and at short circuit output condition, or for high-side SR configuration.

G3687CF is offered in SOP8 package.

Features

- ◆ Integrated 85V Power MOSFET
- ◆ Suitable for DCM, QR and CCM
- ◆ Supports both High-side and Low-side Rectification
- ◆ Wide Output Range down to 3V
- ◆ Supports USB PD + PPS
- ◆ No need for Auxiliary Winding or external power supply
- ◆ Ringing Detection Prevents False Turn-on during DCM and Quasi-Resonant Operations
- ◆ 10nS Fast Turn-off delay and 30nS Turn-on delay
- ◆ Accurate secondary side built-in MOSFET V_{SW} sensing
- ◆ Anti-interference with digital isolation
- ◆ SOP8 Package Available

Applications

- USB PD Quick Chargers
- Power adapter
- Flyback Power Supplies with Very Low and/or Variable Output Voltage

Typical Applications

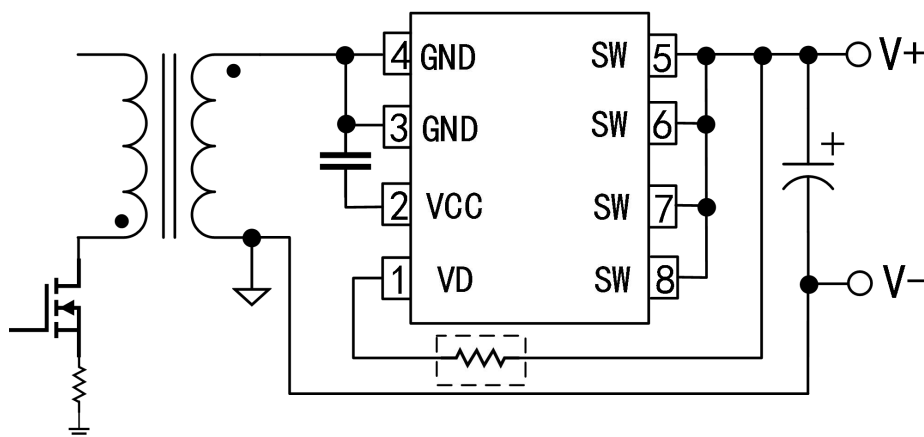

G3687CF

Fast Turn-Off Intelligent Synchronous Rectifier

2. Products Information

2.1 Pin configuration

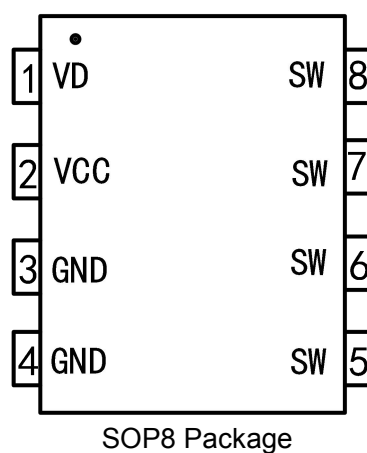

Fig.1. G3687CF Pin Configuration

Pin Num	Pin Name	I/O	Description
1	VD	I	MOSFET drain voltage sensing. VD is also used as the linear regulator input. A resistance of 100Ω can be placed between VD and Drain.
2	VCC	P	Power supply. Bypass a capacitor between VCC and GND.
3,4	GND	P	Ground. GND is also used as a MOSFET source sense reference for SW.
5,6,7,8	SW	O	MOSFET Drain Pin.